

900

RPM

8-Pole, 230/460 Volt
3-Phase, 60 Cycle

Quick Facts

- Ideal Shakeout Vibrator for Foundries
- High Capacity Feeder Drive
- Suitable Drive for Large Screeners
- Replace Old Belt Driven Type Shaker Drives
- Quiet Operating, Dust Tight, Continuous Duty Rated

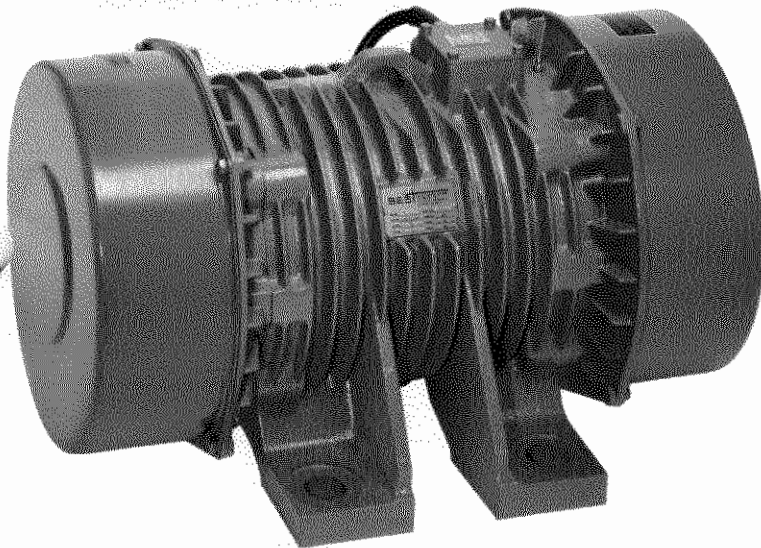

MODEL BE-7700-8 SHOWN ABOVE

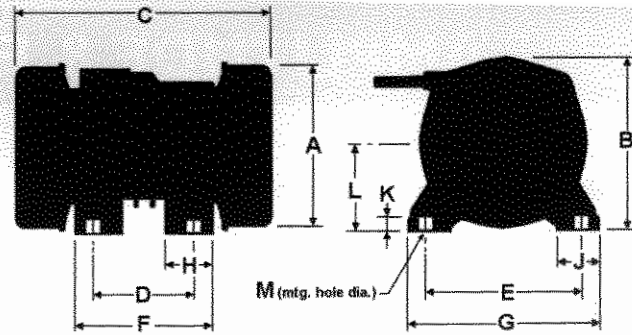

Drawing A

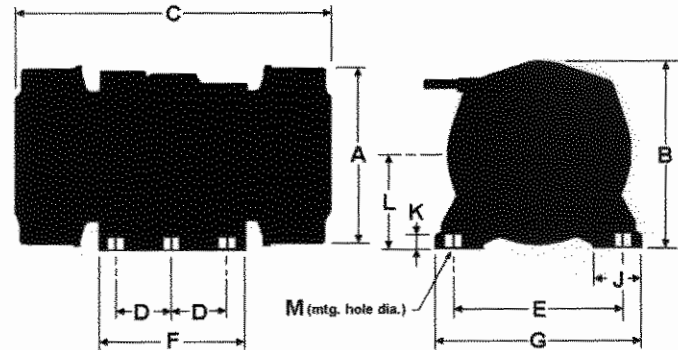

Drawing B

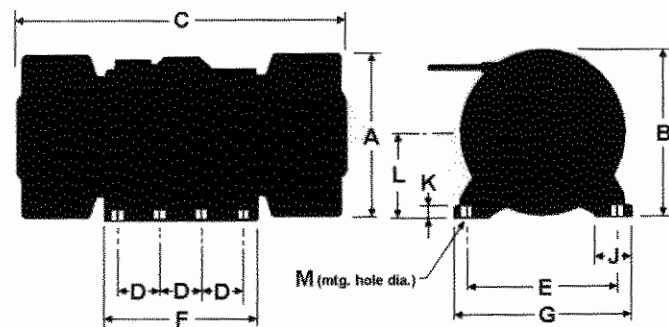

Drawing C

MODEL	H.P.	MAX FORCE (lbs)+	DRWG. REF.	DIMENSIONS (inches)											FULL LOAD AMPS AT		WT. (lbs.)	UN-BALANCE (inch-lbs)	
				A	B	C	D	E	F	G	H	J	K	L	M	230v.			460v.
BE-1100-8	1/2	1,100	A	8-7/8	9-15/32	14-9/16	5-33/64	8-21/32	7-1/2	10-5/8	2-9/16	2-3/8	23/32	4-23/32	13/16	2.4	1.5	100	50.9
BE-1606-8	4/5	1,606	A	9-21/32	10-1/4	15-3/8	5-33/64	9-29/64	7-7/8	11-13/16	2-31/32	2-3/4	13/16	5-1/8	1-1/32	3.3	2.0	130	74.3
BE-2200-8	1	2,200	A	10-7/16	11-1/32	17-23/32	5-29/32	10-15/64	8-9/32	12-19/32	3-5/32	2-3/4	13/16	5-19/32	1-1/32	4.9	3.3	175	102.0
BE-4400-8	2	4,400	A	11-5/8	12-19/32	21-21/32	6-11/16	12-13/64	9-15/32	14-31/32	3-3/4	3-11/32	1-1/8	6-7/32	1-5/16	7.5	4.4	300	203.0
BE-7700-8	3	7,700	A	13-19/32	14-3/8	26-3/8	8-21/32	13-25/32	11-13/16	16-15/16	—	3-15/16	1-5/16	7-9/32	1-17/32	9.5	5.5	465	356.0
BE-9240-8	4	9,240	A	13-19/32	14-3/8	28-3/4	8-21/32	13-25/32	11-13/16	16-15/16	—	3-15/16	1-5/16	7-9/32	1-17/32	9.5	5.5	486	403.0
BE-13200-8	5	13,200	B	15-9/16	16-11/32	28-3/4	4-59/64	14-31/32	13-7/8	18-1/8	—	4-5/32	1-5/16	8-9/32	1-17/32	14.6	8.6	660	610.0
BE-16940-8	6	16,940	B	15-9/16	16-11/32	32-3/4	4-59/64	14-31/32	13-7/8	18-1/8	—	4-5/32	1-5/16	8-9/32	1-17/32	15	7.5	803	783.0
BE-22000-8	8	22,000	B	18-5/16	18-23/32	33-7/8	5-33/64	17-21/64	14-9/16	20-7/8	—	4-15/16	1-1/2	9-15/32	1-25/32	25	15	1070	1017.0
BE-27500-8	10	27,500	C	20-9/32	20-11/16	39-3/8	5-33/64	18-29/32	20-3/32	22-7/16	—	4-15/16	1-1/2	10-7/16	1-25/32	31	18	1420	1272.0
BE-33000-8	12	33,000	C	20-9/32	20-11/16	40-15/16	5-33/64	18-29/32	20-3/32	22-7/16	—	4-15/16	1-1/2	10-7/16	1-25/32	37	22	1560	1526.0
BE-40700-8	15	40,700	C	22-1/16	22-7/16	39-3/4	5-33/64	20-15/32	20-3/32	24-1/32	—	4-15/16	1-1/2	11-7/16	1-25/32	43	26	1800	1882.0

- 900 RPM motors are dual voltage, either 230 volt or 460 volt 3-phase. Specify voltage when ordering. 575 available on special order.
- All 900 RPM motors are rated for continuous duty at the maximum force setting.

- 50 cycle motors are available for all 900 RPM motors. Consult factory for pricing and availability.
- + Factory preset at 100% of maximum force. All units are totally adjustable by a simple setting change on the eccentric weights.